

STEEL WINDOWS
& DOORS



YERENA
IRON WORKS

Passion & Innovation
are the principles
of our work.

Contents

05	History and Commitment
07	Therm Steel Art
18	Galvanized Steel
24	Processes

—

YERENA Iron Works





STEEL WINDOWS & DOORS







A family commitment to innovation and excellence.

YERENA Iron Works opened its doors with an established passion and vision insight into the world of custom doors & windows. Our experience in the industry has taught us to appreciate the uniqueness and personal aspect of each and every of our projects.

Our customer-oriented vision and attention to detail drives us to continually invest in research and development to innovate our products in technology and design.

Our goal is to keep our clients informed each step of the way.



CUSTOM THERMALLY BROKEN STEEL WINDOWS & DOORS





Therm Steel Art

THE NEW GENERATION



Elevate your construction projects with our state - of - the - art, thermally insulated profiles that blend cutting - edge innovation with sleek design. Crafted with the highest quality galvanized and stainless steel, our profiles set new industry standards for door and window construction, offering unmatched structural integrity and a refined appearance. Designed for discerning clients who demand the best in quality and design, our profiles guarantee your project stands out for its innovation, elegance, and commitment to sustainability.

Experience the ultimate fusion of form and function, and let our profiles transform your vision into reality with unmatched style and efficiency.



Galvanized Thermal Steel

CHARACTERISTICS:

Folding windows: openings in and out.

Opening type: folding leaf and double leaf.

–

Windows that open to the outside, casement, vertical pivoting window, horizontal pivoting window.

PLANT VIEW ▼

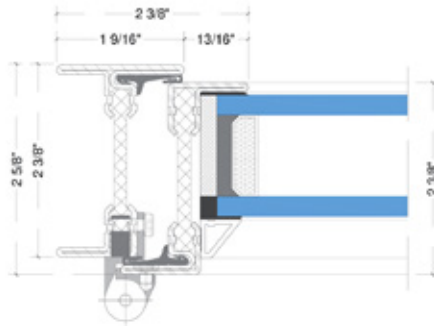

SIDE VIEW ►

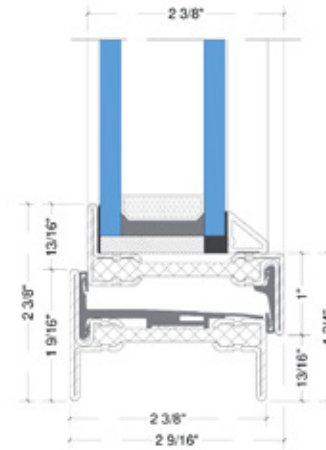

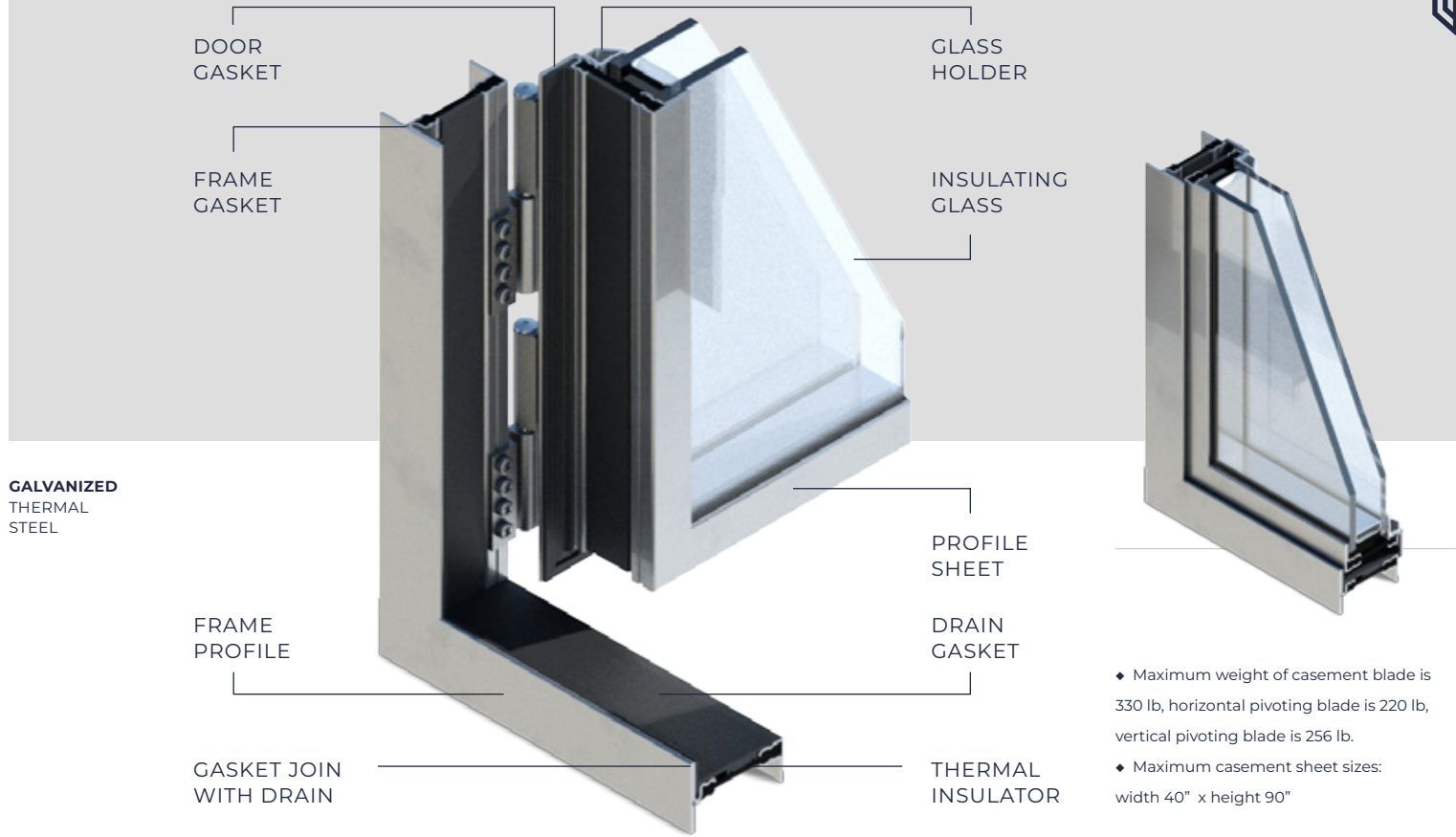

Therm Steel Art

Single and double-leaf doors that open inwards and outwards.

- ◆ Narrow face widths
- ◆ With a threshold or designs without a door sill
- ◆ Mortise lock or multipoint lock



Therm Steel Art horizontal pivot and vertical pivot windows

Offering versatile individual opening types that can open inwards or outwards.

These windows support leaf weights of up to 120 kg and are CE marked for sizes up to 1570 x 1570 mm.

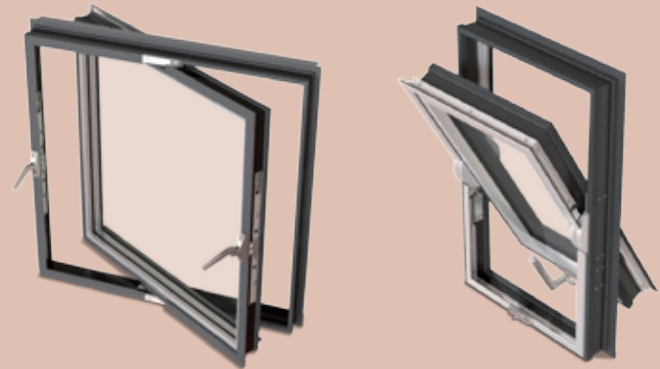

Therm Steel Art sliding doors

Utilizing the sleek steel profile system of Therm Steel Art, we can craft expansive sliding doors with minimal face widths, ensuring exceptional stability.

This offers architects and developers the opportunity to create large glass fronts.



- ◆ Unit sizes of up to 3000 x 2500 mm (W x H)
- ◆ Max. weight of 150 kg per leaf
- ◆ Insulating glass of 20 to 34 mm
- ◆ Uw value of 1.5 W/m²K

- ◆ Welded steel half profiles in combination with glass fibre-reinforced high-performance plastics (100% recyclable)
- ◆ Profile face widths of just 40 mm ensure increased light penetration and also enhance the energy efficiency of the building
- ◆ Sound reduction of up to 41 dB

THERMAL
GALVANIZED
STEEL

—





Quality and distinction.

Whether in residential construction, commercial properties, or renovation projects, our distinguished, combinable profile series of thermal galvanized steel and thermal stainless steel will meet the most arduous requirements for thermal insulation, while still providing the aesthetic charm your property demands.

Furthermore, all our products exceed the industry standard in terms of security, mechanical strength, and durability.



UF Values

CHART AND DESCRIPTIONS

Refer to the chart below for the U values corresponding to the various applications for **Therm Steel Art**.

These values are based on the following materials:

- ◆ Strip galvanized steel profiles, uncoated
- ◆ Aluminum glazing beads (stainless steel with angle glazing bead)
- ◆ Glazing with sealing.



PART 01

UF Values

Infill elements



TYPE OF PROFILE

	≥ 24 mm	≥ 28 mm	≥ 36 mm	≥ 46 mm	≥ 28 mm	≥ 28 mm	≥ 46 mm	≥ 46 mm	◀ 1
					450 103 	450 103 	450 103 	450 103 	◀ 2
						450 104 		450 104 	◀ 3
	2,6 W/m2k	2,4 W/m2k	2,3 W/m2k	2,3 W/m2k	2,2 W/m2k		2,0 W/m2k		◀ 4
	2,1 W/m2k	2,0 W/m2k	2,0 W/m2k	1,9 W/m2k	1,9 W/m2k		1,8 W/m2k		
	1,6 W/m2k	1,8 W/m2k	1,8 W/m2k	1,8 W/m2k	1,5 W/m2k		1,4 W/m2k		

UF Values

CHART AND DESCRIPTIONS

Fixed lights and doors inward opening.

NOMENCLATURE:

1. Glass thickness
2. Insulated profile in the glazing rebaste
3. Insulated profile in both the frame and the glazing
4. The transmittance measurement



PART 02

UF Values

Infill elements



TYPE OF PROFILE

	≥ 24 mm	≥ 28 mm	≥ 36 mm	≥ 46 mm	≥ 28 mm	≥ 28 mm	≥ 46 mm	≥ 46 mm	◀ 1
					450 103 	450 103 	450 103 	450 103 	◀ 2
						450 104 		450 104 	◀ 3
	2,0 W/m2k	1,8 W/m2k	1,8 W/m2k	1,8 W/m2k	1,7 W/m2k		1,6 W/m2k		◀ 4
	1,8 W/m2k	1,7 W/m2k	1,7 W/m2k	1,7 W/m2k	1,6 W/m2k		1,5 W/m2k		
	1,2 W/m2k	1,2 W/m2k	1,1 W/m2k	1,1 W/m2k	1,1 W/m2k		1,1 W/m2k		

Galvanized Steel

MODERN LINE

Our rectangular hollow profile sections, at gauge 12 and 14, offer superior efficiency compared to black carbon steel profiles in terms of torsional rigidity, compression resistance, and corrosion. These profiles boast an excellent weight - to - resistance ratio and feature perfectly shaped corners, allowing for the creation of well - designed doors and windows.

PLANT VIEW ▼

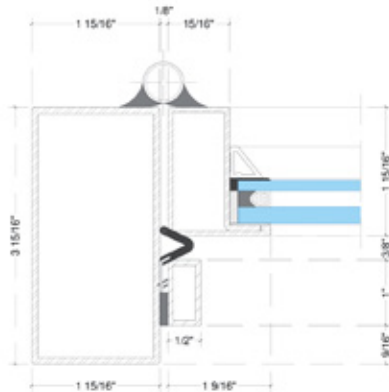

SIDE VIEW ▼

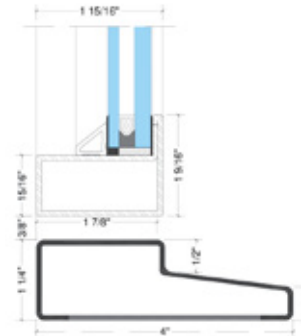

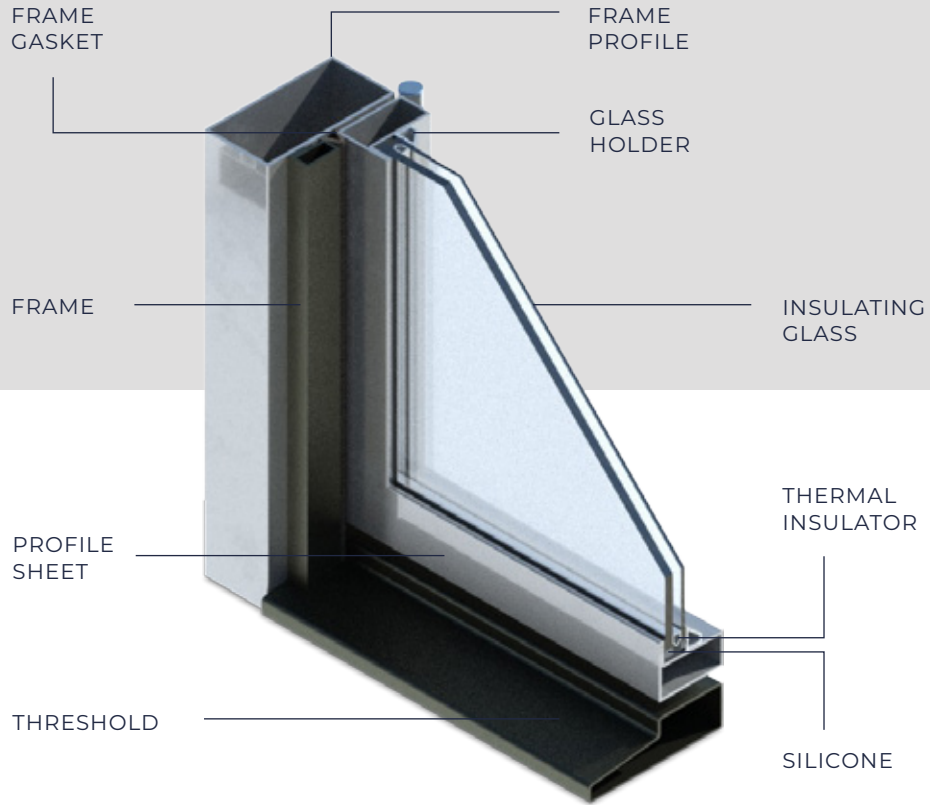

**GALVANIZED
STEEL**



Galvanized steel profiles in strips.

- ◆ Profiles depth 2".
- ◆ Opening in and out.
- ◆ Weight of leaves up to 330 lb.
- ◆ Hardware and accessories.
- ◆ Single and double leaves.

Pivot Door

Discover our exclusive pivot doors
crafted using our state - of - the - art
Modern Line profiles.

Our pivot doors are designed to redefine entryways, offering a seamless blend of functionality and aesthetics. Engineered to provide a striking visual impact, these doors not only exude modern elegance but also ensure exceptional performance.

Each pivot door is meticulously manufactured using our signature profiles, guaranteeing longevity and contemporary appeal.



Elevate your space with our pivot doors, where innovation meets timeless design.

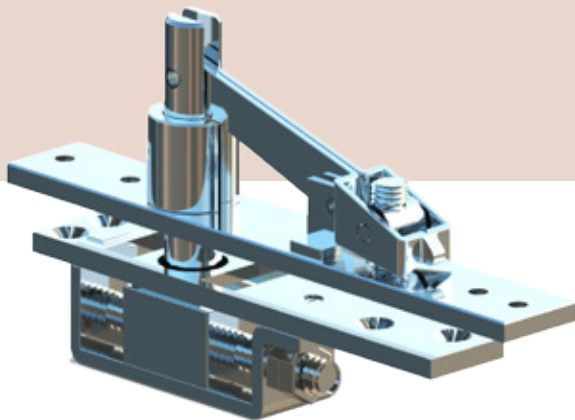

PIVOT
DOOR

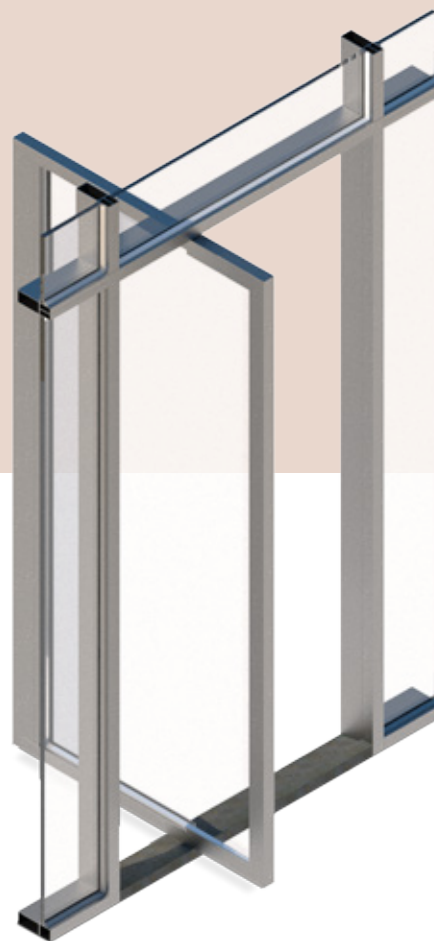

Brass Threshold

The threshold serves a vital role in shielding against water, drafts, and snow infiltration, effectively separating the interior and exterior of a building to bolster thermal efficiency and ensure interior comfort and dryness. Our choice of brass threshold pieces is renowned for their durability and aesthetic design.

We elevate these brass thresholds with a distinctive patina finish, infusing them with character and sophistication that enhance their natural beauty.

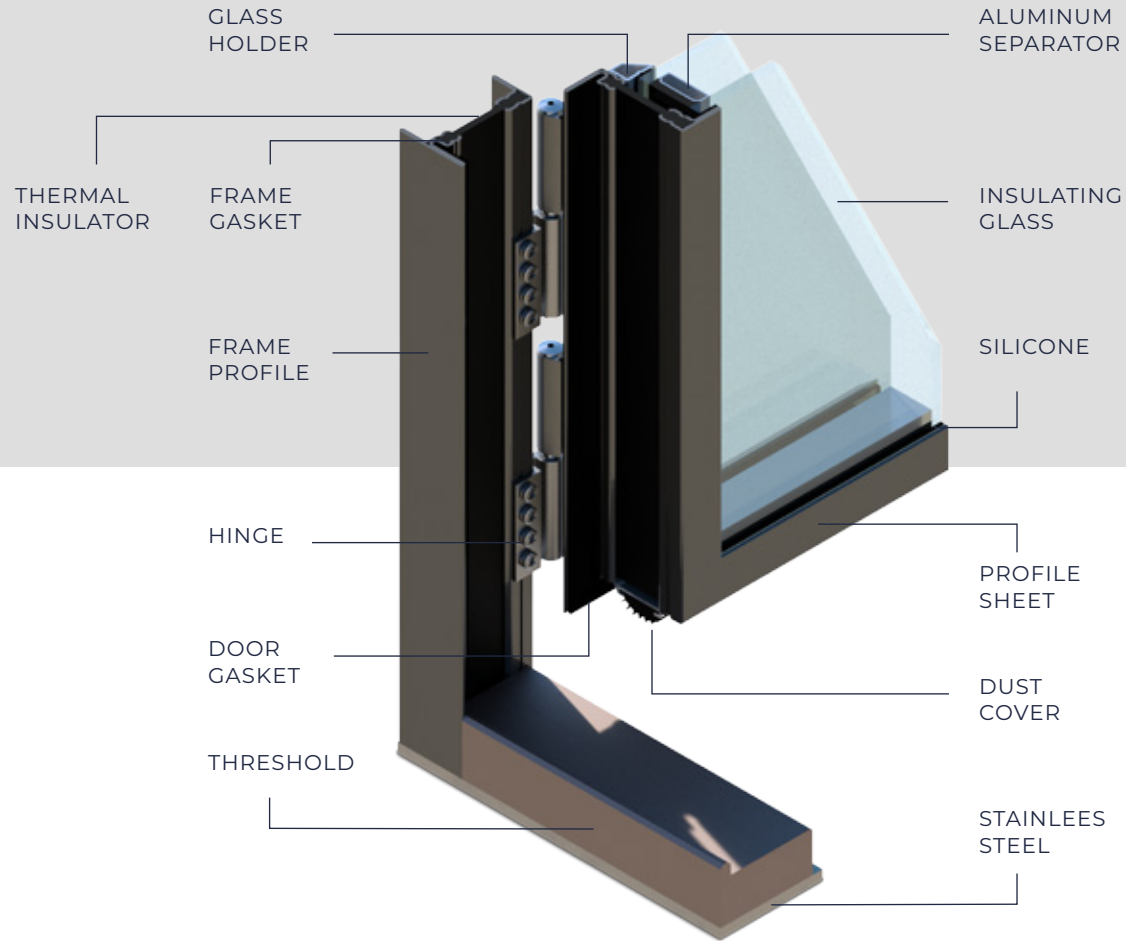

EXPERIENCE

—

Crafting beauty and
security in every detail.

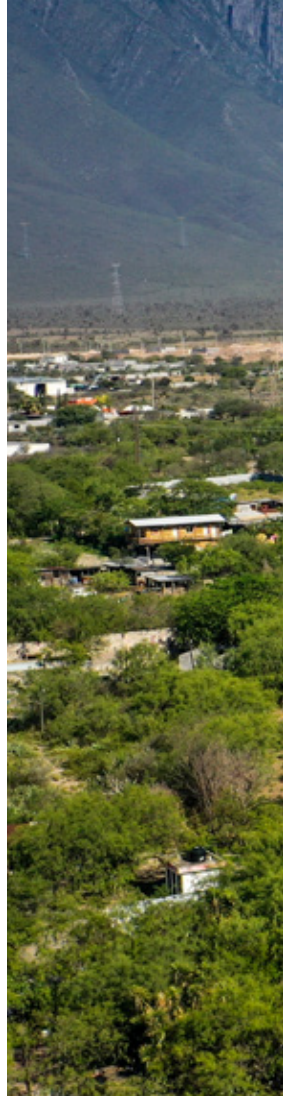







THE PAINTING PROCESS

At **YERENA** Iron Works, our powder coating and liquid painting processes not only helps to express the style of each project, but also protects the metal as needed. This crucial painting process ensures maximum durability for our windows and doors.

FUNCTIONALITY

—

Easy and safe to hook in, intuitively adjustable and extremely visually appealing: this is how the maintenance - and lubricant - free 3D+ screw - on hinge is presented.

Additionally, hinges can also be welded for added customization.

EVERYTHING
IS IN THE DETAILS

—





Each unit is handcrafted, making each piece unique and a one-of-a-kind masterpiece.

-

Est. 2002



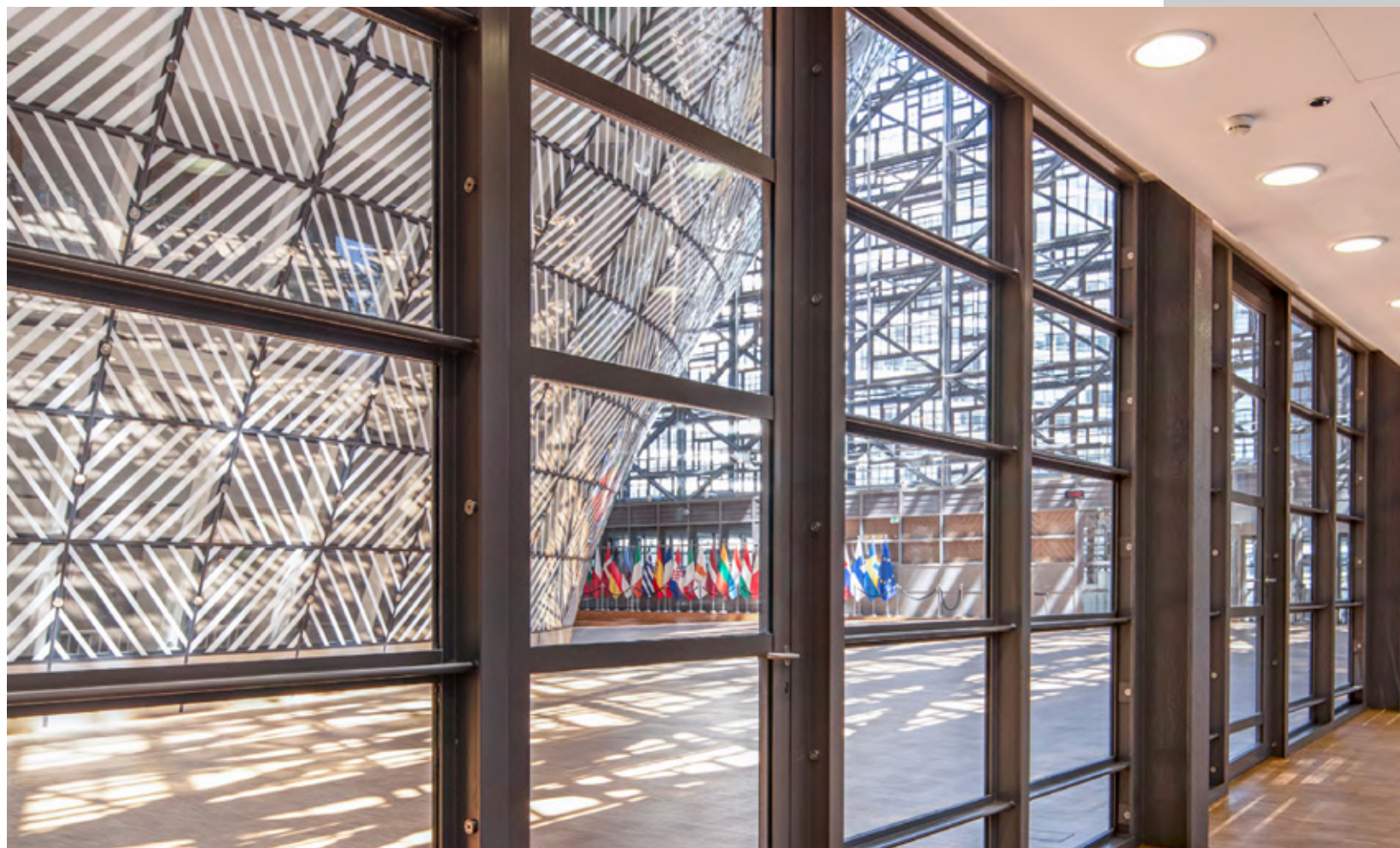



FINISHING & ASSEMBLY

The last step of the production process is finishing and assembly with the Yerena Iron Works craftsmen putting the final touches.

Their notable expertise earned through years of experience and their passion for creation completes production.

Each unit is handmade making every piece one-of-a-kind.



DELIVERY

—

Final assembly & packaging for safe delivery

**STEEL WINDOWS
& DOORS**

—

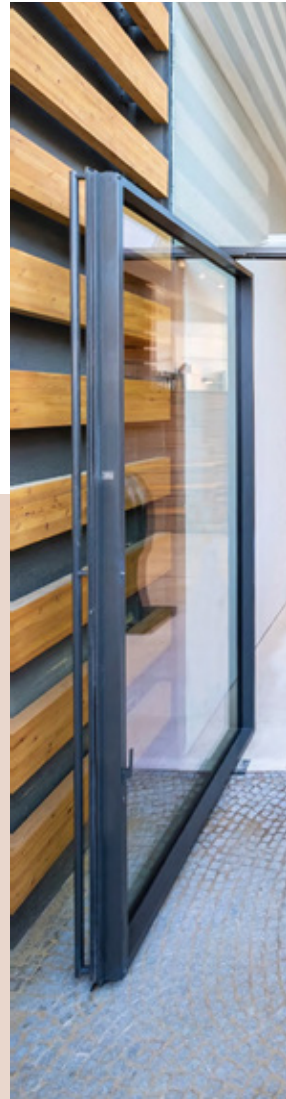



The units are placed in the finished products warehouse & the merchandise is ready to be shipped.

-



Est. 2002



YERENA Iron Works

We believe quality is about much more than the finished product. It's about everything from the material to the small details, and our people who create with passion. For us, it is a way of life & our philosophy – a goal to evoke emotions that clients can feel in our handmade products.

Contact us for custom windows and doors.





info@
YERENAIIRONWORKS.COM

